

BLHB60

ondrives

Precision Gears

Spiral Bevel Gearboxes

20mm Input Bore • 20mm Output Bore • T_{2n} 25-35Nm **1:1 - 2:1**

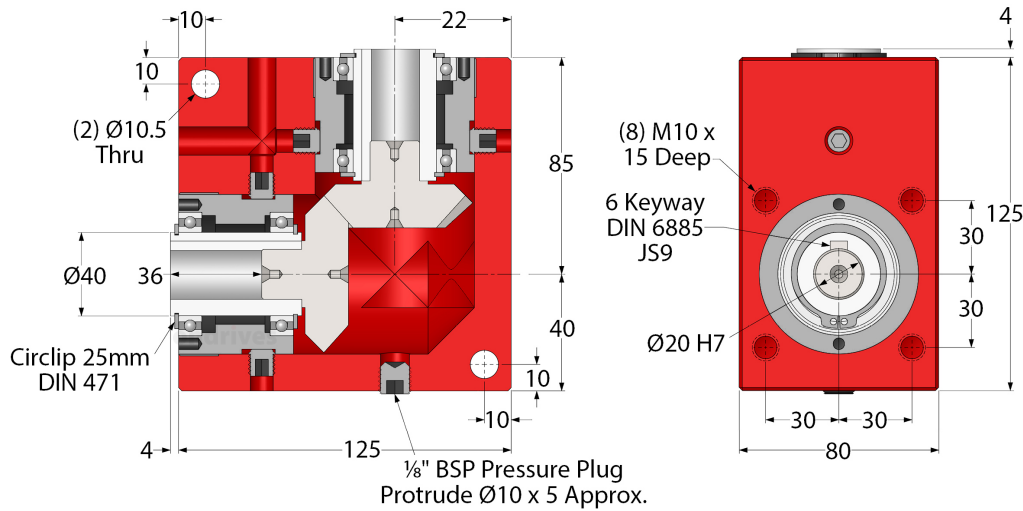
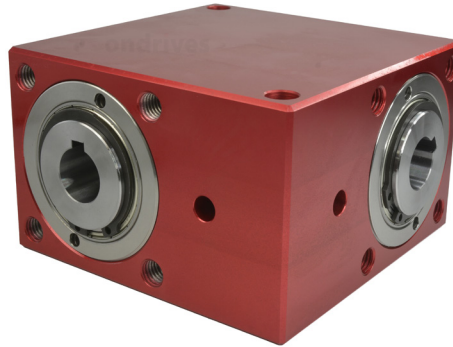
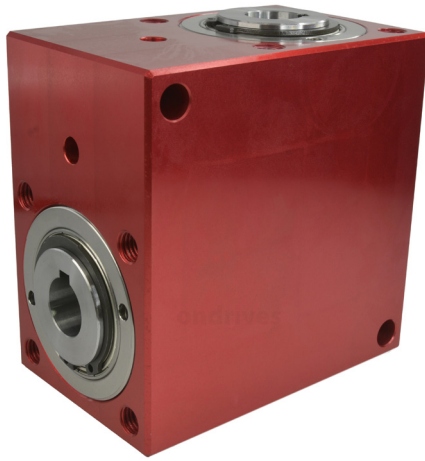

	Part Numbers					
Output Backlash j	Output Backlash j A	Output Backlash j AR	Gear Ratio i	Efficiency η_z	Reflected Inertia at Input	
$\leq 0.75^\circ$	$\leq 0.50^\circ$	$\leq 0.166^\circ$		n1nom	kg·m ²	
BLHB60-1	BLHB60-1A	BLHB60-1AR	1:1	88%	1.99×10^{-4}	
BLHB60-2	BLHB60-2A	BLHB60-2AR	2:1	88%	3.87×10^{-5}	

Weight: 4.5kg.

Nom. Input Speed [S5 T_{2n}] n1nom: 1,000 min⁻¹ (r/min)

Max. Input Speed n1max: 3,000 min⁻¹ (r/min)

Lubrication: Grease Shell Gadus S2 V220AD 2

Lubrication Temperature: Max. Operating $\approx 60^\circ\text{C}$

Max. Input Radial Load F_{r1} : 300N.

Max. Output Radial Load F_{r2} : 300N.

Max. Input Axial Load F_{a1} : 150N.

Max. Output Axial Load F_{a2} : 150N.

Testing in your application is necessary.

You will need to assess duty cycles and confirm suitability with your own calculations.

Figures listed are for guidance only.

Cooling may be needed dependent on application.

ondrives

Precision Gears

T: +44 1246 455500

sales@ondrives.com www.ondrives.com

Updated March 2024 subject to change for use as a guide only.

Spiral Bevel Gearbox

Spiral Bevel Gearboxes

20mm Input Bore • 20mm Output Bore • T_{2n} 25-35Nm **1:1 - 2:1**

BLH Series Spiral Bevel Gearbox

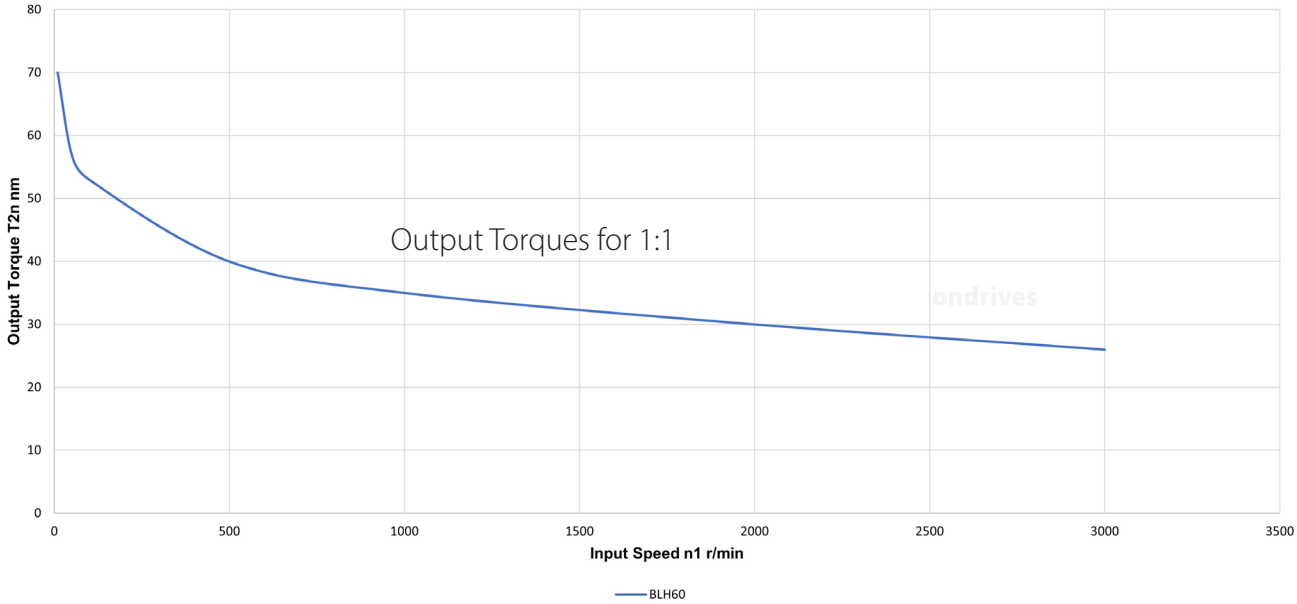

BLH Series Spiral Bevel Gearbox

